

УДК 612.466.6-616.612



Maria Luisa QUERQUES, Federica RAVERA, Alberto MENEGOTTO, Giacomo COLUSSI
Nephrology, Dialysis and Renal Transplant Unit, A.O. Ospedale Niguarda-Ca' Granda, Milan, Italy

GITELMAN SYNDROME: A CLINICAL AND MOLECULAR OVERVIEW

Summary. Gitelman syndrome (OMIM #263800) is an autosomal recessive renal tubular disorder due to loss of function mutations of *SLC12A3* gene, encoding the thiazide-inhibitable, electroneutral $\text{Na}^+\text{-Cl}^-$ cotransporter (NCC) of the distal convoluted tubule. Clinical consequences include chronic normotensive hypokalemic alkalosis, hypomagnesemia, hypocalciuria, polyuria/nocturia, chronic asthenia, muscular cramps, chondrocalcinosis and rarely cardiac arrhythmias.

Impaired reabsorption of glomerular filtrate through NCC drives compensatory reabsorption of Na^+ in more distal tubular segments (connecting and cortical collecting tubules) via both the «electrogenic» channel *ENa* (which also enhances tubular secretion of potassium and protons, explaining the hypokalemic alkalosis), and pendrin-dependent electroneutral NaCl reabsorption. Thus volume depletion is seldom severe in these patients. There exists wide variability and severity of clinical symptoms between subjects, ranging from an almost asymptomatic disease to a severely disabling one. More than 400 *SLC12A3* mutations have been so far described, evenly distributed along the protein sequence and without any hot spot. Mutation detection rate by gene sequencing actually is about 80%. There are no genotype-phenotype correlations.

Commonly considered a benign condition, Gitelman syndrome may be associated with reduced quality of life, increased medicalization and high hospitalization rate.

Key words: Gitelman syndrome, renal tubulopathy/tubular disorder, *SLC12A3* gene, $\text{Na}^+\text{-Cl}^-$ cotransporter, hypokalemia, hypocalciuria, metabolic alkalosis, chondrocalcinosis, tetany.

Definition and epidemiology

Gitelman syndrome (GS; OMIM # 263800) is a renal tubular disorder mechanistically linked to impaired function of the electroneutral $\text{Na}^+\text{-Cl}^-$ cotransporter (NCC) expressed in the apical membrane of distal convoluted tubule (DCT) cells. NCC is the product of the member 3 of the solute carrier family 12 (*SLC12A3*, locus 16q13), and is the target of the thiazide diuretics.

Autosomal recessive loss of function mutations of *SLC12A3* are the cause of GS, though exceptional case reports describe acquired disease in adults, possibly secondary to selective (immunologic) damage of DCT (Kim et al., 2008). Genetic GS is a monogenic disorder, thus it might be more properly defined as Gitel-

man disease. Patients with mutations of *CLCNKB* gene (a basolateral chloride channel) may present with a «Gitelman» phenotype (see below), but they represent a variant or subtype of Bartter syndrome (i.e. salt wasting tubulopathy secondary to Henle's loop defect).

GS is widespread throughout human races; the prevalence of pathogenetic mutations in the general caucasian populations is estimated at 1%, which results in about 25 affected patients p.m.p.

© Maria Luisa Querques, Federica Ravera, Alberto Menegotto, Giacomo Colussi, 2015

© «Нирки», 2015

© Заславський О.Ю., 2015

Pathophysiology of deranged distal nephron Na/fluid reabsorption in GS

The DCT, the connecting tubule (CNT) and the cortical collecting tubule (CCT) are the site of reabsorption of about 5–7 % of glomerular filtrate. Reabsorptive mechanisms differ in DCT and CNT/CCT, though both are finely and reciprocally tuned to meet the control of blood volume and of potassium and acid-base balance (Kahle et al., 2008; Boyden et al., 2012). Na^+ reabsorption through NCC in DCT is equimolar with Cl^- , and operates as a regulator of extracellular fluid volume; Na^+ reabsorption via ENaC in the principal cells of the CCT downstream the DCT is electrogenic and drives potassium and proton secretion, constituting a potent defence against hyperkalemia and acidosis (Figure 1). A complex

system of intracellular proteins expressed in DCT and CCT (comprising the WNK kinases and the Khelk-like and Cullin ubiquitination system) (Boyden et al., 2012) induces, in response to still poorly understood regulators, preferential expression of NCC and/or ENaC (Kahle et al., 2008). Patients with unregulated overactivity of NCC (i.e. pseudohypoaldosteronism type 2) secondary to mutations of WNK1 and 4, KLHL3 or CUL3 have volume dependent hypertension, hyperkalemia and acidosis. On the contrary loss of function mutations of NCC (i.e. GS) are associated with reduced extracellular volume (as indicated by hyperreninemia), due to incomplete compensation of the salt-losing defect in more distal sites of the nephron, and low or low-normal blood pressure (Cruz et al., 2001; Sartori et al., 2007). Also he-

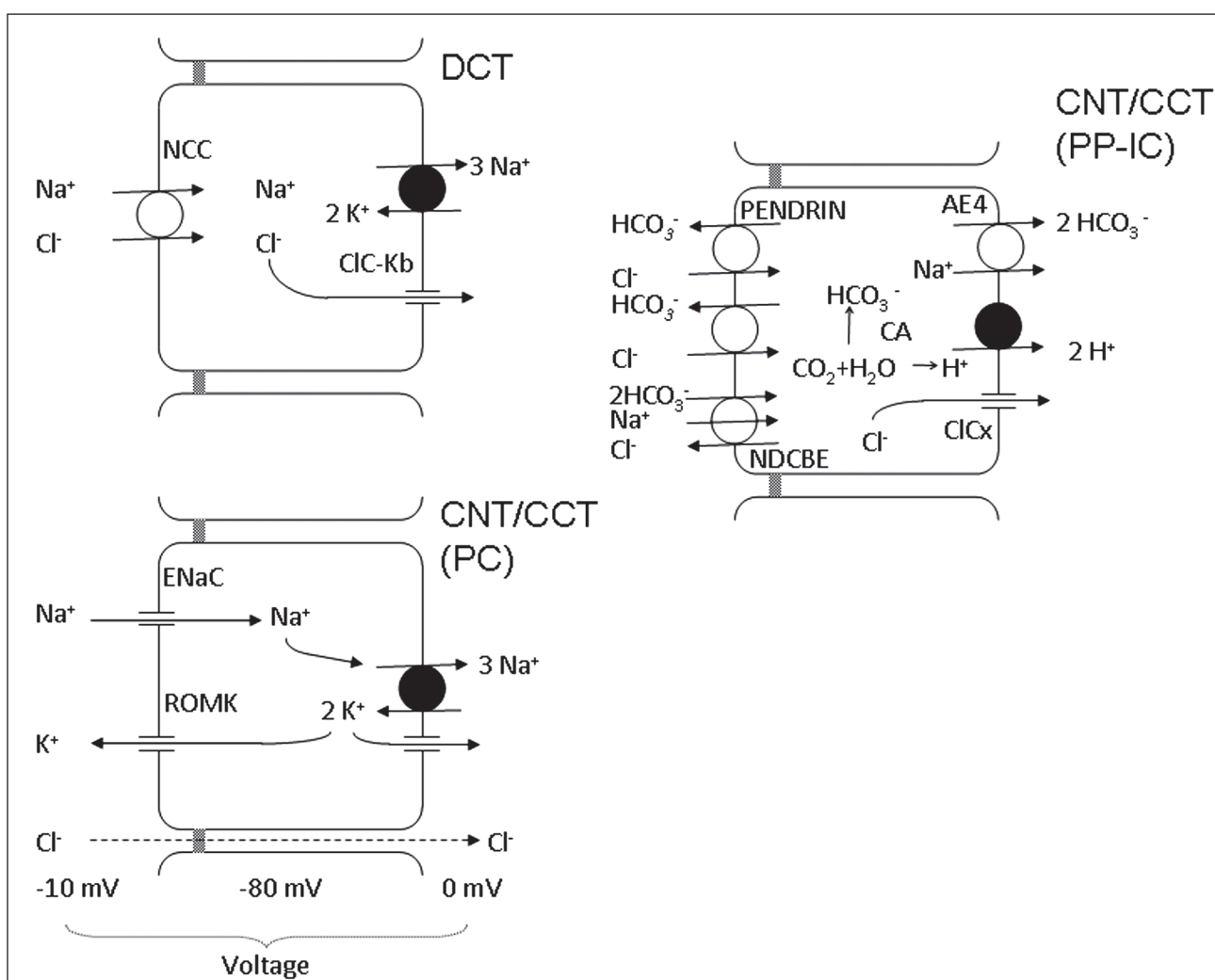

Figure 1. Schematic representation of reabsorptive mechanisms of Na^+ and Cl^- in the Distal Convoluted Tubule (DCT) and in Connecting Tubule/Cortical Collecting Tubule (CT/CCT) principal cells (PC) and pendrin-positive intercalated cells (PP-IC). Tubular lumen is on the left and peritubular space on the right. NCC is the electroneutral Na/Cl cotransporter, ENaC is the Electrogenic Na transporter, ROMK is the potassium channel, ClC-Kb is the basolateral chloride channel, NDCBE is the sodium-dependent chloride/bicarbonate cotransporter, AE4 is the anion-exchanger 4, ClCx is an undefined chloride channel. Basolateral $3\text{Na}^+/2\text{K}^+$ -ATPase and H^+ -ATPase are shown in black. CA is carbonic anhydrase. In the CT/CCT poor permeability to Cl^- is the base for a negative luminal electric gradient favouring tubular secretion of positively charged ions K^+ and H^+ (not shown). In PP-IC the net effect of luminal and basolateral transports is electroneutral NaCl reabsorption with zero base balance

terozygous carriers of NCC mutations have been reported to have lower blood pressure than wild-type carriers (Fava et al., 2008).

In GS NCC mutations result in reduced NaCl reabsorption in DCT, which drives electrogenic Na⁺ reabsorption downstream this tubular segments, mostly the CNT and CCT, enhancing potassium and proton secretion, which is the basis for the typical hypokalemic alkalosis in GS. An additional compensatory mechanism for NaCl reabsorption occurs in CNT/CCT, consisting in the expansion of a subtype of β -intercalated cells expressing in luminal membrane pendrin, a Cl⁻-HCO₃⁻ exchanger: the coupled activity of pendrin and a second Na-dependent Cl⁻-HCO₃⁻ cotransporter results in net NaCl reabsorption (Figure 1) (Grimm et al., 2015). Bicarbonate luminal secretion through pendrin is also an explanation for limitation of the degree of metabolic alkalosis in GS (usually very mild) and the usual occurrence of bicarbonaturia in these patients (with urine pH ranging from 7 to 7.6).

Other poorly understood reabsorptive derangements occur in GS, i.e. renal-type hypomagnesemia and normocalcemic hypocalciuria. Hypocalciuria appears not related to DCT events, and has been shown to result from increased tubular reabsorption in the proximal tubule (Nijenhuis et al., 2005), as determined by micropuncture studies in thiazide-treated rats and being unaffected in animals knocked-out for the Ca channel TRPV5, which drives active Ca reabsorption in DCT.

Hypomagnesemia is likely a consequence of reduced abundance of the magnesium channel TRPM6 in DCT, as described in rats treated with thiazide diuretics or knocked-out for NCC (Nijenhuis et al., 2005). It should be appreciated that loss of function of NCC (as a consequence of mutation, knocking out of NCC or its kinase SPAK — see below, or diuretic inhibition) results in profound anatomical remodeling of DCT (which undergoes hypotrophy) and CNT (which increases in length and abundance in both principal cells and pendrin-positive intercalated cells) (Loffing et al., 2004; Grimm et al., 2025). Thus, there exists an anatomical basis for both reduced reabsorptive function of DCT (for NaCl and Mg) and compensatory activity of CNT/CCT.

Though GS may be viewed as a chronic diuretic state, there are specificities of GS in comparison with chronic diuretic users (Colussi et al., 1992b): patients with GS, like patients with Bartter syndrome, show «resistance» to angiotensin II and other vasoconstrictors (and indeed do not have peripheral vasoconstriction) (Sartori et al. 2007), and, at variance with diuretic users, have normal GFR and are not hyperuricemic; this finding is useful to differentiate GS from «pseudo-Bartter» syndrome from surreptitious diuretic intake (Colussi et al., 1992b). It is unclear whether the absence of renal vasoconstriction in GS, despite relative hypovolemia, may be explained by enhanced renal prostaglandin production (Sartori et al., 2007).

Na balance is usually preserved in GS, at least on common western dietary Na intakes and up to as low as

50 mmol/day (personal data), and «hypovolemic crises» usually do not occur in the absence of superimposed conditions, such as protracted diarrhoea and/or vomiting.

NCC structure and biology

NCC belongs to the cation-chloride cotransporter (CCC) family SLC12; members of this family perform secondary active, electroneutral transport of Cl⁻-coupled Na⁺ and/or K⁺ across the cell membrane. NCC is a 1030 amino acid protein and shares with all CCCs 12 highly conserved alpha helices in the central hydrophobic transmembrane domain (TM) and intracellular hydrophilic amino- and carboxy-terminals rich in phosphorylation sites (Mastroianni et al. 1996) (Figure 2). Glycosylation is necessary for NCC function and surface expression: among the conserved phosphoacceptor sites in the N-terminus, Thr60, when phosphorylated itself, functions as a permissive factor, allowing phosphorylation of other residues in the amino-terminus, and is critical for full NCC activity, but not for trafficking (Richardson et al., 2008). Thr60 is a common mutated residue in GS patients (Maki et al., 2004) and patients homozygous for this mutation showed reduced urinary excretion of total NCC (Yang et al., 2013). Phosphorylation in the extracellular loop between TMs 7 and 8 appears necessary for surface expression (Hoover et al., 2003; Kunchaparty et al., 1999).

The functional unit of NCC is a homodimer (De Jong et al., 2003); the last residue in the protein, Gln1030, could be part of a protein-protein motif (Glaudemann et al., 2012). Additionally, NCC in vivo appears to assemble into multimeric structures of about 700 and 400 kDa residing in the apical plasma membrane together with the scaffold protein γ -adducin (the 700 kDa complex) or in intracellular vesicles (the 400 kDa complex). The cytoskeletal membrane protein γ -adducin might modulate NCC activity by binding to residues in the N-terminus (Dimke et al., 2011).

For correct protein routing and insertion into the cell membrane proper folding during synthesis and glycosylation of NCC are required. A series of surveillance mechanisms remove aberrant products from the cell, among which the endoplasmic reticulum-associated degradation (ERAD) that captures proteins that fail to overcome quality controls (Needham et al., 2011).

Many loss-of-function mutations identified in GS cause the retention of a non-glycosylated protein inside the cell (Kunchaparty et al., 1999; De Jong et al., 2003; Sabath et al., 2004).

Membrane NCC expression and activity is critically dependent upon phosphorylation by a serine/threonine kinase signalling cascade involving SPAK and WNK1 and WNK4 kinases; this signalling cascade is sensitive to intravascular volume depletion and dietary sodium restriction, possibly through angiotensin II, aldosterone and adrenergic factors (Grimm et al., 2015). Once activated, WNK kinases bind to and phosphorylates SPAK, which then interacts with and activates/phosphorylates NCC. In the absence of phosphorylation by SPAK NCC

remains inactive. Mice made KO for SPAK are phenotypically identical with NCC-KO animals (Grimm et al., 2015).

NCC overactivity does occur as a result of deranged activity of this regulation system, such as in pseudohypaldosteronism type 2, a mirror condition to GS. If decreased/abolished NCC activity might occur as a result of abnormal regulation, in the absence of NCC mutations, is still unknown. Zhang et al. (2013) described heterozygous missense mutations of WNK1 in 2 patients with GS features; however they also had a SLC12A3 heterozygous mutation, making this finding inconclusive.

SLC12A3 gene and mutations in GS

The gene encoding for NCC, SLC12A3, is located on chromosome 16q13 and the exon-intron organization reveals 26 exons spanning 55 Kb of genomic DNA (Mastroianni et al., 1996; Simon et al., 1996). All SLC12 family's genes encode for electroneutral Cl^- -coupled cotransporters; SLC12A3 is highly conserved during evolution, leading to a high degree of homology with other Na^+ - (K^+) - Cl^- cotransporters of distant species. The major divergence is in the amino-terminal end and in the extracellular loops of transmembrane domains. NCC is expressed in the kidney renal cortex, small intestine, prostate, colon, spleen (Chang et al., 1996) and bone (Moes et al., 2014).

Homozygous and compound heterozygous loss-of-function mutations cause the disease (Simon et al., 1996). There does not exist a preferential target for mutations, except in selected ethnic groups, and mutations

identified in the majority of families provide evidence for private mutations.

It was possible to identify a founder effect for some mutations, such as the splice site mutation downstream exon 9, c.1180+1G>T, observed in several different European countries in subjects with Roma origin (Coto et al., 2004), the duplication of seven base pairs in exon 10, c.1196_1202dup7bp, in subjects from northern Italy and eastern France (Syrén et al., 2010) and a large deletion of the first seven exons of the NCC gene in a large Amish kindred (Cruz et al., 2001).

Till now, more than 400 inactivating mutations have been identified in GS patients (Human Gene Mutation Database, <http://www.hgmd.org/>). The most frequent type is represented by missense mutations targeting conserved amino-acid residues, whereas other types of mutations (nonsense, small insertions/deletions, splice site mutations and complex rearrangements) are less frequent. No mutations have ever been detected in regulatory regions. A genomic sequencing analysis on 448 GS patients performed by Vargas et al. (2011) identified 59 % missense, 16 % small deletions/insertions (14 % frameshift and 2 % in-frame), 13 % splice site, and 6 % nonsense mutations, in addition to 6 % large rearrangements such as whole exon deletions/duplications, detected by Multiplex Ligation-dependent Probe Assay analysis (MLPA).

Conventional DNA sequencing detects mutations in approximately two-thirds of GS patients, with the remaining patients being either mutation-negative or single heterozygote for known mutations (Lo et al., 2011).

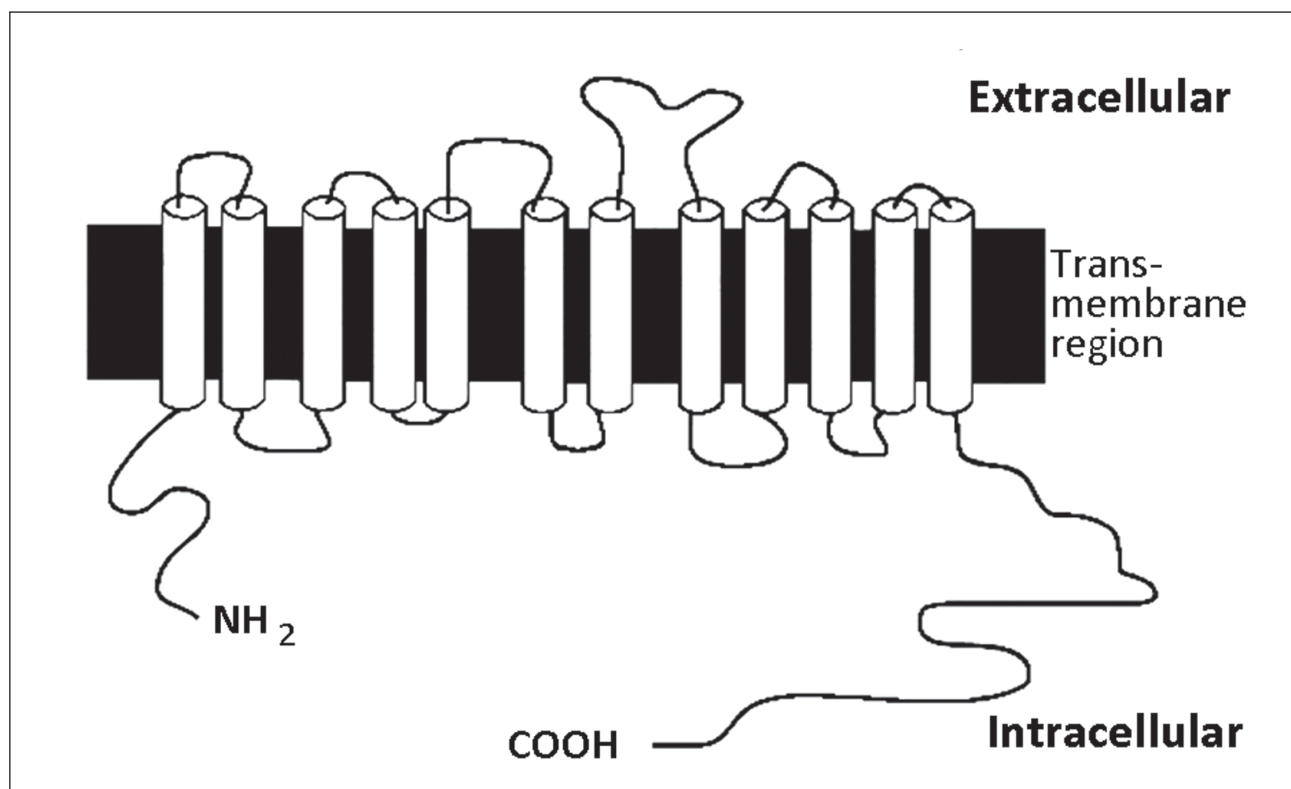

Figure 2. Schematic models of NCC protein. Twelve transmembrane regions, extracellular domains and intracellular tails are shown

Actually, many papers report that only one mutant allele is detected in approximately 20 to 41 % of patients with GS (Nozu et al., 2009). In our own Lab. single heterozygosity detection amounts to 6.6 % of all patients with at least one mutation.

Even by using several techniques (genomic sequencing, MLPA and mRNA analysis itself), the mutation detection rate does not reach more than 80–90 %, which calls into question the accuracy of the clinical diagnoses on the one hand and raises the possibility of involvement of other genes on the other hand (Vargas et al., 2011).

Clinically and biochemically GS and «classic» Bartter syndrome may overlap, so, it has become common practice to screen the *CLCNKB* gene in suspected GS patients who do not harbour mutations in the *SLC12A3* gene. This adds further complexity and burden to the genetic diagnosis of GS.

Expression studies have been performed to evaluate the effect of mutations on NCC function by using the *X. laevis* oocyte heterologous expression system (Kunchaparty et al., 1999; Sabath et al., 2004). Missense mutated NCCs, when transfected in *X. laevis* oocytes, show three distinct patterns: lack of plasma membrane expression with positive cytoplasmic localization, normal transport activity and reduced molecular weight as compared to wild type protein (about 110 kDa vs 140 kDa), indicating abnormal glycosylation and trafficking; cytoplasmic and plasma membrane expression, molecular weight as wild type protein but reduced transport activity; and cytoplasmic and plasma membrane localization, preserved molecular weight but no transport activity.

In general, at least five possible mechanisms by which mutations might reduce/abolish transporter activity have been suggested (Sabath et al., 2004): 1) impaired protein synthesis: mutants leading to decreased protein stability, i.e. nonsense, splice sites, frameshift and deletions; 2) impaired protein processing: proteins are retained in the ER and degraded due to misfolding or abnormal glycosylation; 3) partially impaired routing to plasma membrane of a functional protein; 4) impaired functional property: the cotransporter is inserted into the plasma membrane but lacks proper transport activity; 5) accelerated protein removal from the membrane or degradation: this implies poorly-defined interactions with the activity regulation system.

Clinical signs and symptoms

Gitelman et al. were the first to differentiate, among patients with normotensive hypokalemia from tubular origin, a group of patients with profound hypomagnesemia and hypocalciuria, whom they suggested to have a different condition than Bartter's (Gitelman et al., 1966). Observations from Bettinelli et al. (1992) confirmed that calcium excretion differentiates patients with primary normotensive hypokalemic metabolic alkalosis into two distinct phenotypes, hypercalciuric patients with supposedly Henle's loop defect and hypocalciuric patients with supposedly DCT defect (Bet-

tinelli et al., 1992). Distinctive features included early onset manifestation in the former, with polyhydramnios/premature delivery in the mother, and polyuria/polydipsia, growth retardation, nephrocalcinosis in affected children; the latter condition showed later onset, with hypomagnesemia and tetany/muscular cramps as main symptoms.

Clinical onset of GS usually occurs from infancy to late adulthood, most commonly because of muscular cramps/tetany, often heralded by a febrile illness, or polyuria/nicturia. As awareness of GS increases in the medical community, detection through routine electrolyte blood determinations in apparently healthy people is becoming increasingly common. A retrospective prevalence of common complaints in patients with confirmed genetic diagnosis is shown in Table 1. There appears to be poor correlation between clinical symptoms and biochemistry (both hypokalemia and hypomagnesemia), as well as great variability of type/severity of symptoms between subjects, even with the same mutations (e.g. in families with more than one member affected). A minority of patients present major complaints, being a barrier to proper everyday duties, including extreme weakness, fainting, disturbances of vigilance, major cardiac arrhythmias; diffuse tetany may also be of great subjective and objective concern. A gender effect on symptom severity has been suggested (Riveira-Munoz et al., 2007). Adults might be more symptomatic than children (Table 1).

Final height is usually within population range in GS, with rare exceptions, though in children growth may be somewhat late for age.

In adults chondrocalcinosis is becoming increasingly recognized; it is usually associated with painful recurrent acute arthritis of major joints (knee, ankle, shoulder), presence of calcium pyrophosphate crystals in synovial fluid, and calcific deposits within articular cartilages as shown by US, plain X-ray or CT. Though hypomagnesemia is supposed to play a pathogenic role, there is poor correlation with plasma magnesium levels, and therapy with magnesium salts does not appear to prevent recurrences (personal observations).

Sudden cardiac death has been rarely described in GS (Scognamiglio et al., 2007); incidence of cardiac arrhythmias may be increased in GS, and ECG shows prolongation of QT interval in a substantial fraction of patients, potentially predisposing to enhanced toxicity of QT-prolonging drugs, such as macrolide antibiotics, antihistamines, cisapride, etc. (Bettinelli et al., 2002). Prospective studies in large series are lacking.

Even though widely considered a benign condition, GS is nevertheless associated with increased medicalization needs and even hospitalization; quality of life, as assessed by validated questionnaires, is worst of that in general population and also in specific disease states, such as arterial hypertension, diabetes mellitus, congestive heart failure and coronary artery disease (Cruz et al., 2001). Though, a recent qualitative analysis in a selected number of young adults with GS shows that adaptation

mechanisms are strong and allow most patients to consider their condition as a «different kind of normality» (Caiata-Zufferey et al., 2012).

No major complaints have been reported concerning pregnancy, both in heterozygous, unaffected mothers of patients with GS, and in affected mothers themselves (Mascetti et al., 2011).

Hypokalemia is likely to be universal in GS (no normokalemic patients with proven mutations have been described), and its detection actually is the main clue leading to the diagnosis; mild, compensated metabolic alkalosis is also common. Hypomagnesemia occurs in about 70 % of the patients, and hypocalciuria in about 80 %. No apparent correlation has been shown between mutation and biochemical phenotype: in families with more than 1 affected member it is not uncommon to observe discrepancies in the occurrence of hypomagnesemia, hypocalciuria or both between affected subjects (personal observations). There may be a time delay for hypomagnesemia to appear: several Authors and ourselves have cared for patients who remained normomagnesemic for several years, to become hypomagnesemic later in life. Plasma calcium levels are normal to slightly increased, this latter anomaly representing increased calcium binding to plasma albumin as an effect of metabolic alkalosis (Colussi et al., 1994a). Plasma ionized calcium is normal, as is bone mineral density, indicating that hypocalciuria is balanced by proportional reduction in calcium absorption (Colussi et al., 1994a). Plasma uric acid is normal to low-normal, and urine uric acid fractional excretion is high normal-slightly increased; this is in striking contrast to people on chronic diuretic intake

(Colussi et al., 1992b). Notwithstanding, we have seen rare patients with genetically proven GS and true hyperuricemia and gout, which was a likely concurrence of distinct diseases.

Diagnosis and differential diagnosis

Diagnosis is based on clinical symptoms (when present), suggestive biochemical profile, functional tests and genetic detection of pathogenic mutations.

Plasma electrolyte profile usually shows hypokalemia (up to lower than 2 mmol/L), high-normal or slightly increased bicarbonate, and normal sodium and chloride. Significant hypochloremia should suggest vomiting or diuretic abuse (Colussi et al., 1992b).

Urine electrolytes show «normal» (i.e. in balance with intake) levels of sodium, potassium, chloride and magnesium (on usual western diets, 100–300 mmol/day sodium and chloride, 60–100 mmol/day potassium, and 70–120 mg/day magnesium) (Colussi et al., 1992a). They are useful for excluding extrarenal causes of hypokalemia and/or hypomagnesemia (e.g. intestinal malabsorption, laxative abuse, cystic fibrosis, proton-pump inhibitors, congenital mutation of the magnesium channel TRPM6, etc.), which display reduced urine potassium (usually less than 15–20 mmol/day) and/or magnesium levels (usually less than 10 mg/day). In surreptitious vomiting (concealed anorexia/bulimia), urine chloride excretion is markedly reduced (usually less than 20 mEq/day) and much lower than sodium excretion, and in surreptitious abuse of diuretics consensual reduction or normal excretion of both sodium and chloride are observed in different phases (i.e. post-abuse and in later anti-natriuretic

Table 1. Presenting symptoms, and overall relative frequency of symptoms in paediatric (< 18 yrs) and adults (> 18 yrs) patients with genetically proven GS

	Paediatrics	Adults
<i>At diagnosis</i>		
n	41	47
Age at diagnosis (median and ranges)	6.0 (0.1–17)	35.5 (18–57)
Tetany/cramps	10 (24 %)	13 (27 %)
Paresis	2 (5 %)	4 (9 %)
Fainting/Exhaustion	1 (2 %)	5 (11 %)
Cardiac arrhythmias	1 (2 %)	5 (10 %)
Growth retardation	5 (12 %)	
Asthenia	3 (7 %)	
Polyuria		1 (2 %)
Diagnosis by chance	19 (46 %)	19 (40 %)
<i>Overall symptoms</i>		
Micturition disorder (enuresis, nocturia, polyuria)	5 (12 %)	25 (53 %)
Muscle disorder (tetany/cramps, paresis)	14 (34 %)	26 (62 %)
Well being (asthenia, poor performance)	5 (12 %)	23 (49 %)
Cardiac arrhythmias	1 (2 %)	10 (21 %)
Neurologic (fainting, cataplexy, exhaustion, paraesthesia)	1 (2 %)	10 (21 %)
Chondrocalcinosis		6 (13 %)
Asymptomatic	16 (39 %)	4 (9 %)

phase). Urines are usually alkaline in GS, with detectable bicarbonate (even though quantitatively less than in vomiting) and negative net acid excretion; this finding reflects the aforesaid activation of pendrin-positive β -intercalated cells along the CNT/CCT, downstream the DCT.

Plasma renin activity is typically increased, and together with normal-low blood pressure differentiates salt-losing tubular disorders from hypertensive, hyporeninemic, hypokalemic disorders such as primary hyperaldosteronism, Liddle syndrome, licorice intake, apparent mineralocorticoid excess, desametasone-suppressible hyperaldosteronism.

Plasma aldosterone is high-normal to slightly increased, though not so high as renin would predict; this is commonly explained by inhibitor effect of hypokalemia on aldosterone secretion. Aldosterone is likely to contribute to hypokalemia and alkalosis in GS by enhancing reabsorptive/secretory activities of principal cells of CCT, and indeed antialdosterone drugs are effective in ameliorating hypokalemia (Colussi et al., 1994b).

The main differential diagnosis of GS is with Bartter syndrome (i.e. salt-losing disorders with a defect in Henle's loop). Age at onset and symptoms usually help identify putative disorder (see Table 2); clinical overlap may exist with the so-called «classical» Bartter syndrome (mostly type 3 and rare type 1 and 2 cases) presenting in adolescence/early adulthood. Magnesium levels are usually normal and calcium excretion high in Bartter patients, but again Bartter syndrome type 3 may associate with both hypomagnesemia and hypocalcemia.

Functional tests with diuretics (thiazides or furosemide) are useful in differentiating GS from Bartter syndrome at large (i.e. DCT from Henle's loop defect)

(Colussi et al., 2007). A thiazide test (50 mg p.o. followed by 6 30-min urine collections) is actually the preferred diagnostic functional test in our Department: a low diuretic-induced rise in Cl^- fractional excretion over basal (less than 2.2 %) usually occurs in more than 90 % of GS patients while in Bartter syndrome the diuretic effect is enhanced (Figure 3). Specificity is not 100 %, since Bartter type 3 patients may also show blunted effect of thiazides as in GS (Nozu et al., 2010). Free water clearance studies are no longer performed in the diagnosis of salt-losing disorders; they showed higher than normal minimal urine osmolality and reduced free water generation in the «distal nephron» (Gill and Bartter, 1978; Colussi et al. 1992a).

Definite diagnosis resides in the documentation of a homozygous/compound heterozygous mutation in SLC12A3 gene by direct sequencing. Due to large variability of described mutations, the whole gene has to be deep sequenced. The mutation detection rate is about 80 %, and may vary according to stringency in criteria for suspecting the disorder, since differential diagnoses are so large. Dosage of NCC in urinary exosomes may prove to be useful, since low to undetectable levels have been observed in most patients with GS but not in other tubular disorders (Joo et al., 2007). This new technology still awaits validation in clinical practice.

Treatment and outcome

GS is a lifelong disorder for which definitive cure is still unavailable. Many patients do not require any intervention, and generic advices, assurance on good long-term prognosis (mostly to parents) and periodic supervision is all that is required. When treatment is felt necessary or useful, it is aimed at correcting plasma le-

Table 2. Summary of genes/proteins mutated in Bartter and Gitelman syndromes, and main clinical differentiating features

	Bartter Syndrome					Gitelman syndrome
	Type 1	Type 2	Type 3	Type 4	Type 5	
Gene name	SLC12A1	KCNJ1	CLCNKB	BSND	CASR	SLC12A3
Protein name	NKCC2	ROMK	ClC-Kb	Barttin	CaR	NCC
Major symptoms	Polyuria/ Tetany/cramps Dehydration/ growth retardation	As for type 1		Variable + deafness (from mild to severe)	As for type 1	Hypocalcemia Muscular cramps Chondrocalcinosis
Age of onset	From birth	From birth	Childhood/ Adolescence	From birth	Childhood	Childhood/ adolescence to adulthood
«Antenatal» phenotype*	+++±	+++	±	+++	--	
Nephrocalcinosis	+++±	+++	±	-	+±	
Urine calcium	+++	+++	variable (from low to high)	±	+++	low

Note: * — «antenatal» phenotype defines massive polyuria in utero (polyhydramnios) and soon after birth.

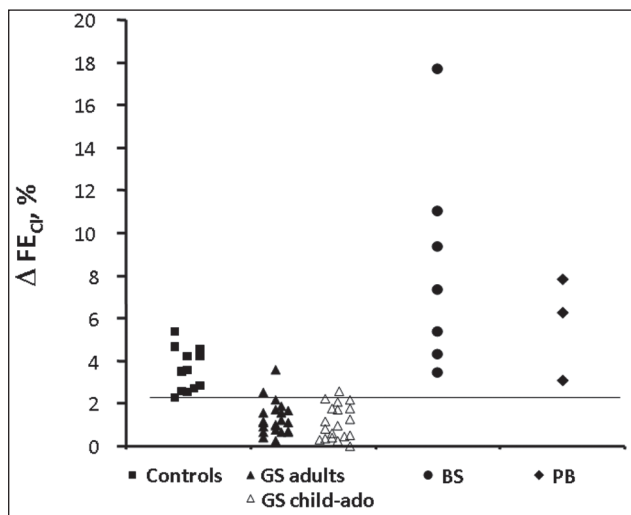

Figure 3. Thiazide test results in control subjects, and patients with chronic normotensive hypokalemia and alkalosis: GS patients with genetically-proven NCC mutations (adults or pediatric); BS patients with mutations in NKCC2 (Barter syndrome type 1, 5 patients) or CLC-Kb (Barter syndrome 3, 2 patients); PB patients with «pseudo-Barter syndrome» secondary to surreptitious furosemide intake. ΔFE_{cr} is the maximum increase over basal of chloride fractional excretion (i.e. chloride clearance over creatinine clearance: $U_{Cl}/P_{Cl} \times P_{Cr}/U_{Cr} \times 100$) after 50 mg hydrochlorothiazide administration. Horizontal line represents the lower normal value of 2.2 %

vels of potassium and magnesium. Oral administration of potassium (preferably as chloride) and magnesium salts rarely, if ever, succeeds alone in achieving sustained normalization blood levels, since urine losses increase with increasing intake. In emergency settings (tetanic crisis, paresis, major cardiac arrhythmias) i.v. potassium chloride and magnesium sulphate are usually effective in symptom resolution. Also in preparation to stressful medical procedures (major and minor surgery, delivery, etc.) it may be safe to maintain an i.v. potassium chloride slow drip infusion (at least 80 mmol/24 hrs) through the whole periprocedural period.

Indications to chronic treatment and benefits of treatment itself are loosely defined; the more symptomatic patients (because of chronic fatigue, lack of energy, or cognitive black outs) report feeling better after treatment. Although symptom severity and hypokalemia do not match, we consider candidates to pharmacologic treatment patients with a blood potassium level lower than 3 mmol/L, due to cardiac and muscle concerns of such a low kalemia; basic approach is with a potassium-sparing diuretic (spironolactone, 50 to 300 mg/day, or amiloride, 10–30 mg/day), with oral potassium chloride (25–50 mmol/day). Plasma potassium increases by a mean of about 0.8 mmol/L (Colussi et al. 1994b), with sustained effect over time. Amiloride is rather less effective. Blood pressure is not consistently affected by this treatment, and patients are able to comply with it for indefinite time. The only

unfavourable effects of spironolactone are painful gynaecomastia in males and oligomenorrhoea in young women. We usually advice women to stop both drugs when planning for a pregnancy. If plasma magnesium is lower than 1.2 mg/dL, oral magnesium salts are also prescribed: long term results of this treatment are unavailable and patient compliance poor.

There is a general trend to encourage GS patients to increase dietary salt, on the supposition of a «salt wasting» state. In fact adult GS are able in general to maintain quite well salt balance, and instead high sodium intake may enhance potassium loss in the CCT. We advice instead our adult patient to restrain from dietary salt as much as possible, and indeed plasma potassium levels are better controlled on restricted than on ad libitum sodium diets.

Chondrocalcinosis is poorly responsive to interventions on plasma potassium and magnesium levels; steroids and non-steroidal anti-inflammatory drugs are most effective in acute attacks, as is colchicine. This latter drug, taken just at the beginning of joint pain and for several days, has proved in our hands most useful in the management of this recurrent complaint.

Rare patients are poorly responsive to «preventive» treatment, and have recurrent episodes of fainting, muscle paresis, general exhaustion requiring i.v. electrolyte repletion. Such rare patients are candidate to planned i.v. infusions in the hospital or at home.

Summary and Key Concepts

Gitelman syndrome is the clinical and biochemical manifestation of impaired function of the electroneutral Na-Cl cotransporter of the renal distal convoluted tubule (NCC), the target of thiazide-class of diuretics.

Homozygous and compound heterozygous loss of function mutations of the SLC12A3 gene cause the disease; more than 400 inactivating mutations (mostly missense mutations) have been identified, without any preferential target

Main biochemical abnormalities include hypokalemia, mild metabolic alkalosis, hypomagnesemia, hyperreninemia, hypocalciuria

Clinical manifestations include muscular cramps/tetanic crisis, asthenia, polyuria/nocturia, chondrocalcinosis; normal/low blood pressure is an important feature in the differential diagnosis with hypertensive hypokalemic disorders

Gitelman syndrome cannot be presently cured, and therapy aims at correcting plasma potassium and possibly magnesium levels with supplemental oral potassium and magnesium, aldosterone-receptor antagonists and the Na-channel blocker amiloride. Intravenous infusions of potassium and magnesium are needed in acute crisis and stressful contexts

Long term prognosis appears good, long term renal function preserved, but quality of life may be somehow impaired, and medicalization/hospitalization rate increased compared to the general population.

The Authors have no conflict of interest to declare.

References

1. Bettinelli A., Bianchetti M.G., Girardin E. et al. Use of calcium excretion values to distinguish two forms of primary renal tubular hypokalemic alkalosis: Bartter and Gitelman syndromes // *Journal of Pediatrics* 1992; 120: 38-43.
2. Bettinelli A., Tosoletto C., Colussi G. et al. Electrocardiogram with prolonged QT interval in Gitelman disease // *Kidney International* 2002; 62: 580-584.
3. Boyden L.M., Choi M., Choate K.A. et al. Mutations in kelch-like 3 and cullin 3 cause hypertension and electrolyte abnormalities // *Nature* 2012; 482 (7383): 98-102.
4. Caiata-Zufferey M., Zanini C.A., Schulz P.J. et al. Living with Gitelman disease: an insight into patients' daily experiences // *Nephrology Dialysis and Transplantation* 2012; 27(8): 3196-3201.
5. Chang H., Tashiro K., Hirai M. et al. Identification of a cDNA encoding a thiazide-sensitive sodiumchloride cotransporter from the human and its mRNA expression in various tissues // *Biochemical and Biophysical Research Communications* 1996; 223: 324-328.
6. Colussi G., Rombolà G., Verde G. et al. Distal nephron function in Bartter's syndrome: abnormal conductance to chloride in the cortical collecting tubule? // *American Journal of Nephrology* 1992a; 12: 229-239.
7. Colussi G., Rombolà G., Airaghi C., De Ferrari M.E., Minetti L. Pseudo-Bartter's syndrome from surreptitious diuretic intake: differential diagnosis with true Bartter's syndrome // *Nephrology Dialysis and Transplantation* 1992b; 7: 896-901.
8. Colussi G., Macaluso M., Brunati C., Minetti L. Calcium metabolism and calciotropic hormone levels in Gitelman syndrome // *Mineral Electrolyte Metabolism* 1994a; 20: 294-301.
9. Colussi G., Rombolà G., Macaluso M., De Ferrari M.E., Minetti L. Correction of hypokalemia with antialdosterone therapy in Gitelman's syndrome // *American Journal of Nephrology* 1994b; 14: 127-135.
10. Colussi G., Bettinelli A., Tedeschi S. et al. A Thiazide Test for the Diagnosis of Renal Tubular Hypokalemic Disorders // *Clinical Journal of the American Society of Nephrology* 2007; 2: 454-60.
11. Coto E., Rodriguez J., Jeck N. et al. A new mutation (intron 9 +1 G>T) in the SLC12A3 gene is linked to Gitelman syndrome in Gypsies // *Kidney International* 2004; 65(1): 25-9.
12. Cruz D., Simon D.B., Nelson-Williams C. et al. Mutations in the Na-Cl cotransporter reduce blood pressure in humans // *Hypertension* 2001; 37: 1458-1464.
13. De Jong J.C., Willems P.H., Mooren F.J. et al. The structural unit of the thiazide-sensitive NaCl cotransporter is a homodimer // *Journal of Biological Chemistry* 2003; 278: 24302-24307.
14. Dimke H. Exploring the intricate regulatory network controlling the thiazide-sensitive NaCl cotransporter (NCC) // *Pflugers Archives-European Journal of Physiology* 2011; 462: 767-777.
15. Fava C., Montagnana M.L., Rosberg L. et al. Subjects heterozygous for genetic loss of function of the thiazide-sensitive cotransporter have reduced blood pressure // *Human Molecular Genetics* 2008; 17(3): 413-418.
16. Gill J.R., Bartter F.C. Evidence for prostaglandin-independent defect in chloride reabsorption in the loop of Henle as a proximal cause of Bartter's syndrome // *American Journal of Medicine* 1978; 65: 766-772.
17. Gitelman H.J., Graham J.B., Welt L.G. A new familial disorder characterized by hypokalemia and hypomagnesemia // *Transactions of the American Association of Physicians* 1966; 79: 221-223.
18. Grimm P.R., Lazo-Fernandez Y., Delpire E. et al. Integrated compensatory network is activated in the absence of NCC phosphorylation // *J. Clin. Invest.* 2015; 125(5): 2136-2150.
19. Hoover R.S., Poch E., Monroy A. et al. N-glycosylation at two sites critically alters thiazidebinding and activity of the rat thiazide-sensitive Na:Cl cotransporter // *Journal of the American Society of Nephrology* 2003; 14: 271-282.
20. Joo K.W., Lee J.W., Jang H.R. et al. Reduced urinary excretion of thiazide-sensitive Na-Cl cotransporter in Gitelman syndrome: preliminary data // *American Journal of Kidney Diseases* 2007; 50: 765-773.
21. Kahle K.T., Ring A.M., Lifton R.P. Molecular physiology of the WNK kinases // *Annual Review of Physiology* 2008; 70, 329-355.
22. Kim Y.K., Song H.C., Kim W.Y. et al. Acquired Gitelman Syndrome in a Patient With Primary Sjögren Syndrome // *American Journal of Kidney Diseases* 2008; 52(6): 1163-67.
23. Kunchaparty S., Palcsó M., Berkman J. et al. Defective processing and expression of thiazide-sensitive Na-Cl cotransporter as a cause of Gitelman's syndrome // *American Journal of Physiology Renal Physiology* 1999; 277: F643-F649.
24. Lo Y.F., Nozu K., Iijima K. et al. Recurrent deep intronic mutations in the SLC12A3 gene responsible for Gitelman's syndrome // *Clinical Journal of the American Society of Nephrology* 2011; 6(3): 630-9.
25. Loffing J. et al. Altered renal distal tubule structure and renal Na⁺ and Ca²⁺ handling in a mouse model for Gitelman's syndrome // *Journal of the American Society of Nephrology* 2004; 15: 2276-2288.
26. Maki N., Komatsuda A., Wakui H. et al. Four novel mutations in the thiazide-sensitive Na-Cl co-transporter gene in Japanese patients with Gitelman's syndrome // *Nephrology Dialysis and Transplantation* 2004; 19(7): 1761-6.
27. Mascetti L., Bettinelli A., Simonetti G.D. et al. Pregnancy in inherited hypokalemic salt-losing renal tubular disorder // *Obstetrics and Gynecology* 2011; 117: 512-516.
28. Mastroianni N., De Fusco M., Zollo M. et al. Molecular cloning, expression pattern, and chromosomal localization of the human Na-Cl thiazide-sensitive cotransporter (SLC12A3) // *Genomics* 1996a; 35: 486-493.
29. Moes D.M., van der Lubbe N., Zietze R., Loffing J., Hoorn E.J. The sodium chloride cotransporter SLC12A3: new roles in sodium, potassium, and blood pressure regulation // *Pflugers Archives-European Journal of Physiology* 2014; 466: 107-118.

30. Needham P.G., Mikoluk K., Dhakarwal P. et al. The Thiazide-sensitive NaCl Cotransporter Is Targeted for Chaperone-dependent Endoplasmic Reticulum-associated Degradation // *Journal of Biological Chemistry* 2011; 286: 43611-43621.
31. Nijenhuis T., Vallon V., Kemp A.W.C.M. et al. Enhanced passive Ca²⁺ reabsorption and reduced Mg²⁺ channel abundance explains thiazide-induced hypocalcemia and hypomagnesemia // *Journal of Clinical Investigation* 2005; 115 (6):1651-1658.
32. Nozu K., Iijima K., Nozu Y. et al. A deep intronic mutation in the SLC12A3 gene leads to Gitelman syndrome // *Pediatric Research* 2009; 66: 590-593.
33. Nozu K., Lijima K., Kanda K. et al. The Pharmacological Characteristics of Molecular-Based Inherited Salt-Losing Tubulopathies // *Journal of Clinical Endocrinology and Metabolism* 2010; 95: doi:10.1210/jc.2010-0392.
34. Richardson C., Rafiqi F.H., Karlsson H.K. et al. Activation of the thiazide-sensitive Na⁺-Cl⁻ cotransporter by the WNK-regulated kinases SPAK and OSR1 // *Journal of Cell Science* 2008; 121(5): 675-84.
35. Riveira-Munoz E., Chang Q., Bindels R.J., Devuyst O. Gitelman's syndrome: towards genotype-phenotype correlations? // *Pediatric Nephrology* 2007; 22: 326-332.
36. Sabath E., Meade P., Berkman J. et al. Pathophysiology of functional mutations of the thiazide-sensitive Na-Cl cotransporter in Gitelman disease // *American Journal of Physiology and Renal Physiology* 2004; 287: F195-F203.
37. Sartori M., Parotto E., Bonso E. et al. Autonomic Nervous System Function in Chronic Hypotension Associated With Bartter and Gitelman Syndromes // *American Journal of Kidney Diseases* 2007; 49(2); 330-335.
38. Scognamiglio R., Negut C., Calò L.A. Aborted sudden cardiac death in two patients with Bartter's/Gitelman's syndromes // *Clinical Nephrology* 2007; 67: 193-197.
39. Simon D.B., Nelson-Williams C., Johnson-Bia M. et al. Gitelman's variant of Bartter's syndrome inherited hypokalaemic alkalosis, is caused by mutations in the thiazide-sensitive NaCl cotransporter // *Nature Genetics* 1996; 12: 24-30.
40. Syrén M.L., Borsa Ghiringhelli N., Bettinelli A. et al. The mutation c.1196_1202dup7bp (p.Ser402X) in the SLC12A3 gene clusters in Italian Gitelman syndrome patients and reflects the presence of a common ancestor // *Nephrology Dialysis and Transplantation* 2011; 26(2): 557-61.
41. Vargas-Poussou R., Dahan K., Kahila D. et al. Spectrum of mutations in Gitelman syndrome // *Journal of the American Society of Nephrology* 2011; 22(4): 693-703.
42. Yang S.S., Fang Y.W., Tseng M.H. et al. Phosphorylation regulates NCC stability and transporter activity in vivo // *Journal of the American Society of Nephrology* 2013; 24: 1587-1597.
43. Zhang C., Zhu Y., Huang F. et al. Novel missense mutations of WNK1 in patients with hypokalemic salt-losing tubulopathies // *Clinical Genetics* 2013; 83: 545-552.

Надійшла 17.05.15,

Надійшла у виправленому вигляді 23.05.15 ■

Glossary

CaR: Ca-sensing receptor**CCT:** cortical collecting tubule**CIC-Kb:** Cl channel Kb (expressed in the basolateral cell membrane of thick ascending limb of Henle's loop and DCT)**CNT:** connecting tubule**CT:** connecting tubule**DCT:** distal convoluted tubule**ENaC:** electrogenic Na channel (expressed in the luminal membrane of CT and CCT)**MLPA:** Multiplex Ligation-dependent Probe Assay analysis (a genetic technology for the genome study)**NCC:** Na⁺-Cl⁻ cotransporter (the target of thiazide diuretics)**NKCC2:** Na⁺-K⁺-2Cl⁻ cotransporter (expressed in the luminal cell membrane of thick ascending limb of Henle's loop and DCT)**ROMK:** renal outer medulla K channel (expressed in the luminal cell membrane of thick ascending limb of Henle's loop, CT and CCT)**SNP:** single nucleotide polymorphism

Corresponding Author:

Giacomo Colussi, M.D.

Division of Nephrology, Dialysis and Renal Transplant Centre

A.O. Ospedale Niguarda-Ca' Granda

Piazza Ospedale Maggiore, 3

20162 Milan, Italy

Giacomo.colussi@ospedaleniguarda.it

Phone +39 02 64442521

Fax +39 02 64442909 ■

Maria Luisa Querques, Federica Ravera,
Alberto Menegotto, Giacomo Colussi
Nephrology, Dialysis and Renal Transplant Unit,
A.O. Ospedale Niguarda-Ca' Granda, Milan,
Italy

Maria Luisa Querques, Federica Ravera,
Alberto Menegotto, Giacomo Colussi
Nephrology, Dialysis and Renal Transplant Unit,
A.O. Ospedale Niguarda-Ca' Granda, Milan,
Italy

Синдром Гітельмана: клінічний і молекулярний огляд

Gitelman Syndrome: a Clinical and Molecular Overview

Резюме. Синдром Гітельмана (OMIM #263800) є автосомно-рецесивним розладом функції каналців внаслідок мутацій гена *SLC12A3*, що кодує тіазид-блокований електронейтральний $\text{Na}^+\text{-Cl}^-$ котранспортер (NCC) дистальних звивистих каналців. Клінічні наслідки включають у себе хронічний нормотензивний гіпокаліємічний алкалоз, гіпомagneмію, гіпокальціурію, поліурію/ніктурію, хронічну астенію, м'язові спазми, хондрокальциноз і рідко — аритмію.

Порушення реабсорбції клубочкового фільтрату через дефіцит NCC призводить до компенсаторної реабсорбції Na^+ в дистальних тубулярних сегментах (з'єднуючі і кіркові збірні каналці) через «електричний» канал *ENa* (що також збільшує каналцеву секрецію калію і протонів, пояснюючи наявність гіпокаліємічного алкалозу) і за рахунок пендринзалежної електронейтральної реабсорбції NaCl . Таким чином, у цих хворих рідко спостерігають тяжку дегідратацію.

Існує велика варіабельність і вираженість клінічних симптомів серед пацієнтів, починаючи від майже безсимптомного захворювання до важкого страждання. До цього часу біло описано понад 400 *SLC12A3* мутацій, що рівномірно розподілені уздовж білкової послідовності і без будь-яких гарячих точок. Частота виявлення мутацій шляхом генної послідовності насправді близька до 80 %. Також не встановлено генотип-фенотипових кореляцій.

Синдром Гітельмана зазвичай вважається доброякісним станом, проте він може бути пов'язаний зі зниженням якості життя, підвищенням потреби в медичній допомозі та збільшенням частоти госпіталізації.

Ключові слова: синдром Гітельмана, ниркова тубулопатія/розлад функції каналців, ген *SLC12A3*, $\text{Na}^+\text{-Cl}^-$ котранспортер, гіпокаліємія, гіпокальціурія, метаболічний алкалоз, хондрокальциноз, тетанія.

Summary. Gitelman syndrome (OMIM #263800) is an autosomal recessive renal tubular disorder due to loss of function mutations of *SLC12A3* gene, encoding the thiazide-inhibitable, electroneutral $\text{Na}^+\text{-Cl}^-$ cotransporter (NCC) of the distal convoluted tubule. Clinical consequences include chronic normotensive hypokalemic alkalosis, hypomagnesemia, hypocalciuria, polyuria/nocturia, chronic asthenia, muscular cramps, chondrocalcinosis and rarely cardiac arrhythmias.

Impaired reabsorption of glomerular filtrate through NCC drives compensatory reabsorption of Na^+ in more distal tubular segments (connecting and cortical collecting tubules) via both the «electrogenic» channel *ENa* (which also enhances tubular secretion of potassium and protons, explaining the hypokalemic alkalosis), and pendrin-dependent electroneutral NaCl reabsorption. Thus volume depletion is seldom severe in these patients.

There exists wide variability and severity of clinical symptoms between subjects, ranging from an almost asymptomatic disease to a severely disabling one. More than 400 *SLC12A3* mutations have been so far described, evenly distributed along the protein sequence and without any hot spot. Mutation detection rate by gene sequencing actually is about 80 %. There are no genotype-phenotype correlations.

Commonly considered a benign condition, Gitelman syndrome may be associated with reduced quality of life, increased medicalization and high hospitalization rate.

Key words: Gitelman syndrome, renal tubulopathy/tubular disorder, *SLC12A3* gene, $\text{Na}^+\text{-Cl}^-$ cotransporter, hypokalemia, hypocalciuria, metabolic alkalosis, chondrocalcinosis, tetany.

Резюме та ключові поняття

Синдром Гітельмана є клінічним та біохімічним проявом порушеної функції електронейтрального $\text{Na}\text{-Cl}$ котранспортера дистальних звивистих каналців (NCC) нирок — місця фармакологічного впливу тіазидних діуретиків.

Захворювання викликають гомозиготні і поєднані гетерозиготні мутації гена *SLC12A3*; ідентифіковано

Summary and Key Concepts

Gitelman syndrome is the clinical and biochemical manifestation of impaired function of the electroneutral $\text{Na}\text{-Cl}$ cotransporter of the renal distal convoluted tubule (NCC), the target of thiazide-class of diuretics.

Homozygous and compound heterozygous loss of function mutations of the *SLC12A3* gene cause the

понад 400 мутації (в основному місенс-мутації) без переважання конкретних локусів.

Основні біохімічні порушення включають гіпокаліємію, слабкий метаболічний алкалоз, гіпомагніємію, гіперренінемію, гіпооксалурію.

Клінічні прояви включають м'язові спазми/тетаничні кризи, астенію, поліурію/ніктурію, хондрокальциноз; нормальний/низький кров'яний тиск є важливою особливістю при диференціальній діагностиці з гіпертензивними гіпокаліємічними розладами.

На сьогодні синдром Гітельмана не може бути вилікуваним, його терапія спрямована на корекцію вмісту калію плазми і, можливо, рівня магнію (за наявності його низької концентрації) шляхом призначення калію і магнію перорально, антагоністів рецепторів до альдостерону і блокатора Na-каналу амilorиду. Внутрішньовенне введення калію і магнію необхідне при гострому кризі і стресових ситуаціях.

Тривалий прогноз з'являється добрим, у довгостроковому спостереженні функція нирок лишається збереженою, але якість життя може бути певним чином порушена і необхідність надання медичної допомоги/госпіталізації збільшена порівняно із населенням в цілому.

Конфлікт інтересів: не заявлений.

disease; more than 400 inactivating mutations (mostly missense mutations) have been identified, without any preferential target.

Main biochemical abnormalities include hypokalemia, mild metabolic alkalosis, hypomagnesemia, hyperreninemia, hypocalciuria.

Clinical manifestations include muscular cramps/tetanic crisis, asthenia, polyuria/nocturia, chondrocalcinosis; normal/low blood pressure is an important feature in the differential diagnosis with hypertensive hypokalemic disorders.

Gitelman syndrome cannot be presently cured, and therapy aims at correcting plasma potassium and possibly magnesium levels with supplemental oral potassium and magnesium, aldosterone-receptor antagonists and the Na-channel blocker amiloride. Intravenous infusions of potassium and magnesium are needed in acute crisis and stressful contexts.

Long term prognosis appears good, long term renal function preserved, but quality of life may be somehow impaired, and medicalization/hospitalization rate increased compared to the general population.

The Authors have no conflict of interest to declare.